

ADC_SiTCP V.3		
Title TOP		
Size A3	Document Number <Doc>	Rev <RevC>
Date:	Tuesday, August 01, 2023	Sheet 1 of 23

813 Parts, 43 Library Parts, 588 Nets, 2896 Pins

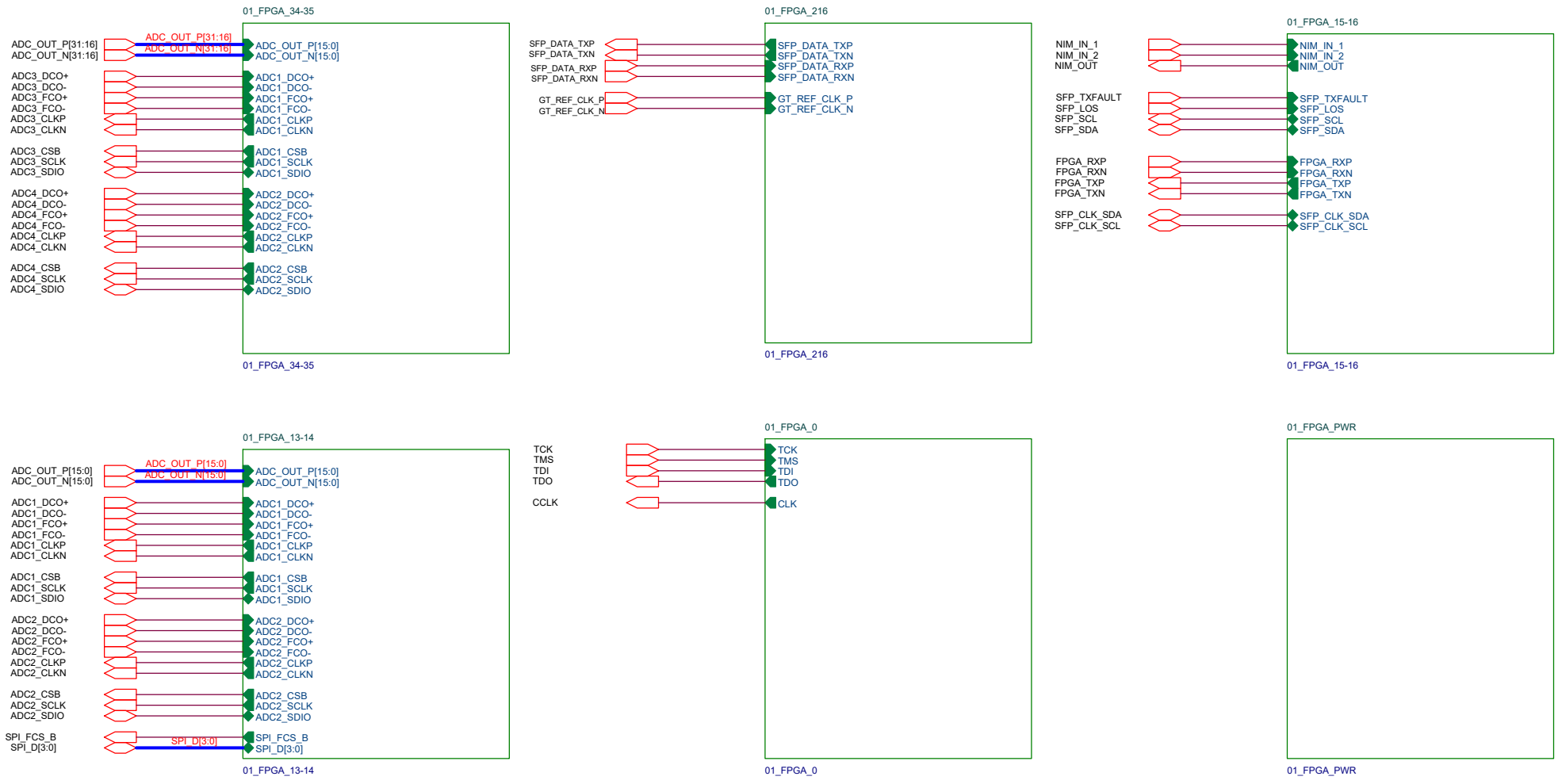

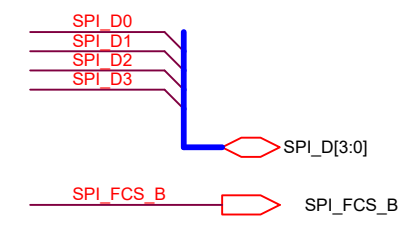

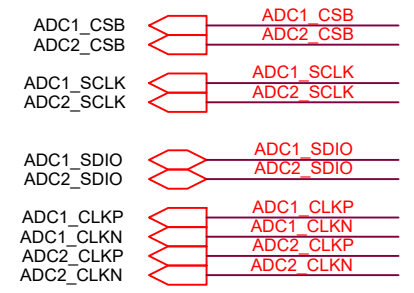
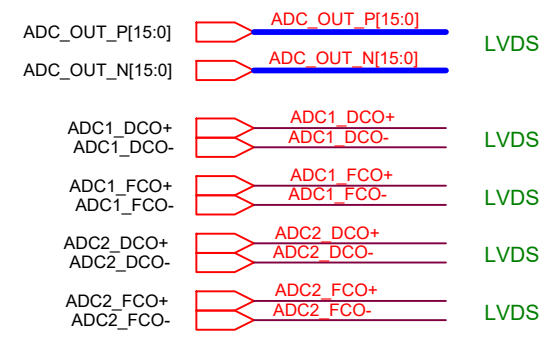
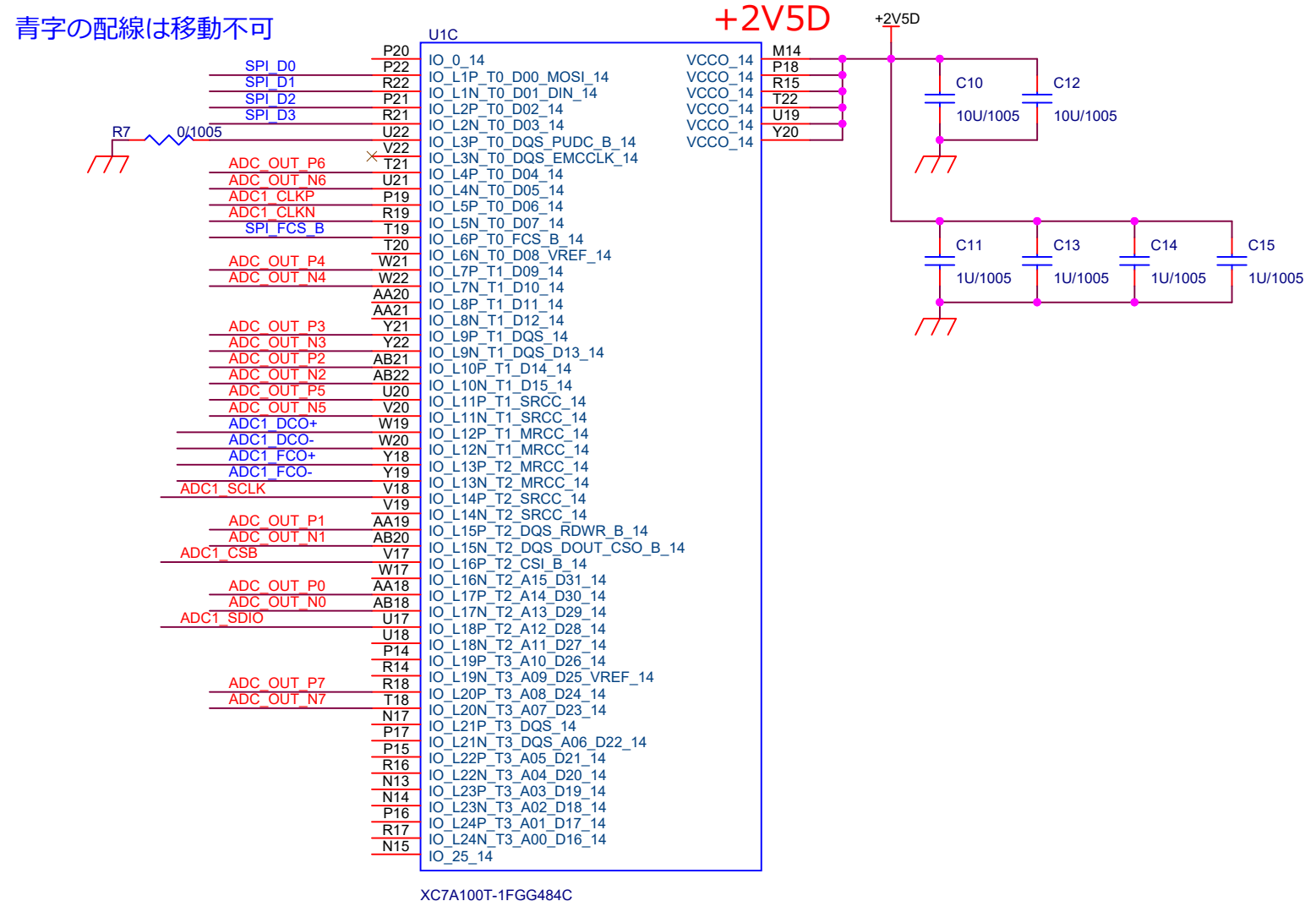
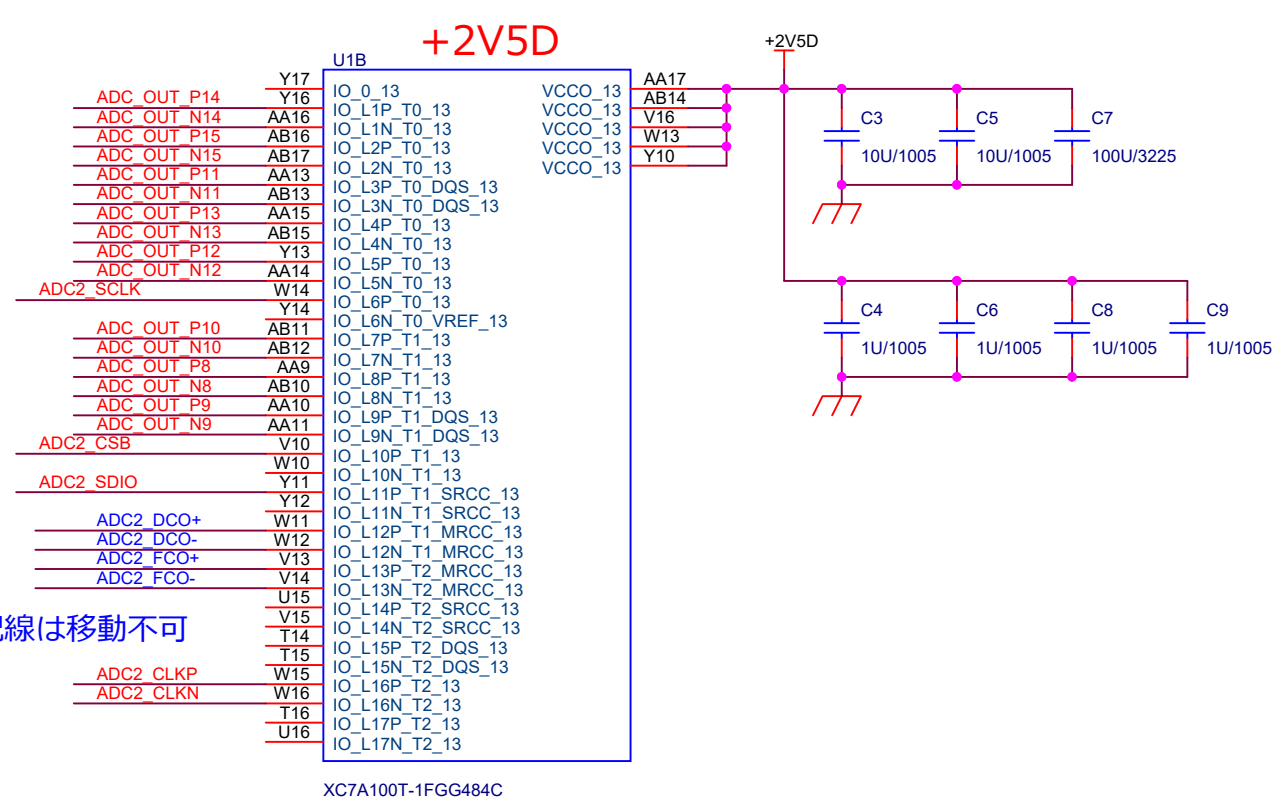
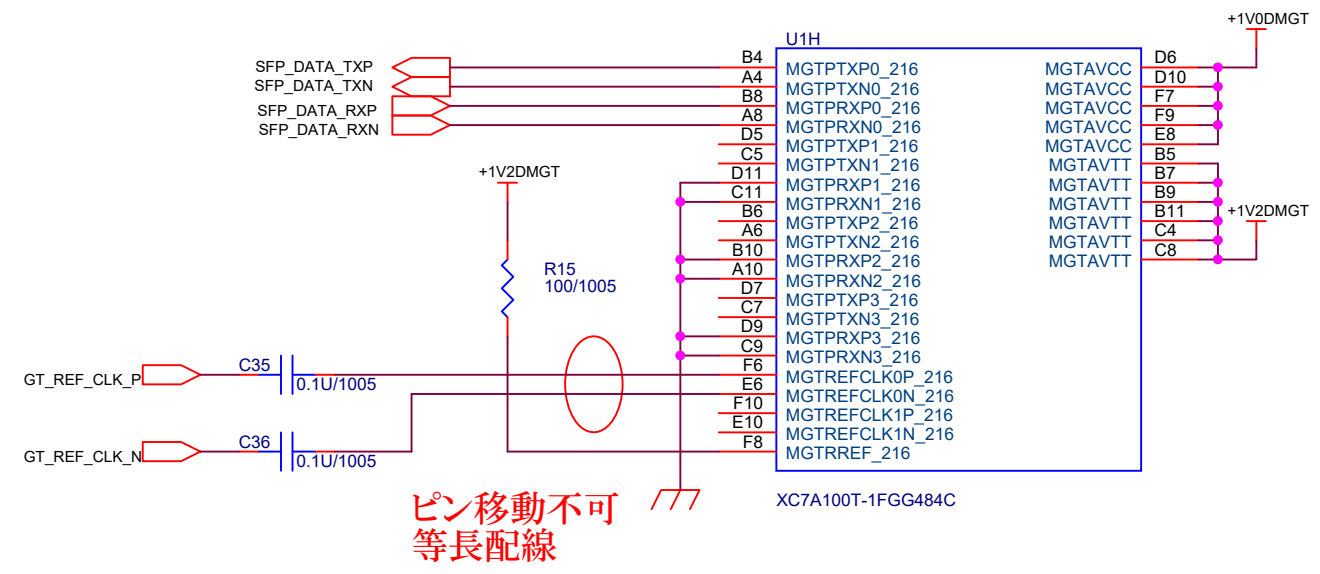

ピン移動不可
等長配線

capacitance (0.1U/1005)
を以下のピン間に配置(電源-GND間)

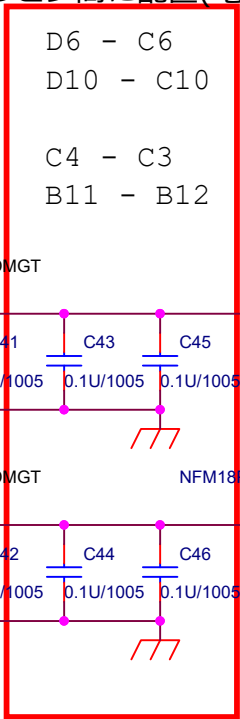

For MGTAVCC (1.0V)

RiseTime about 9msec

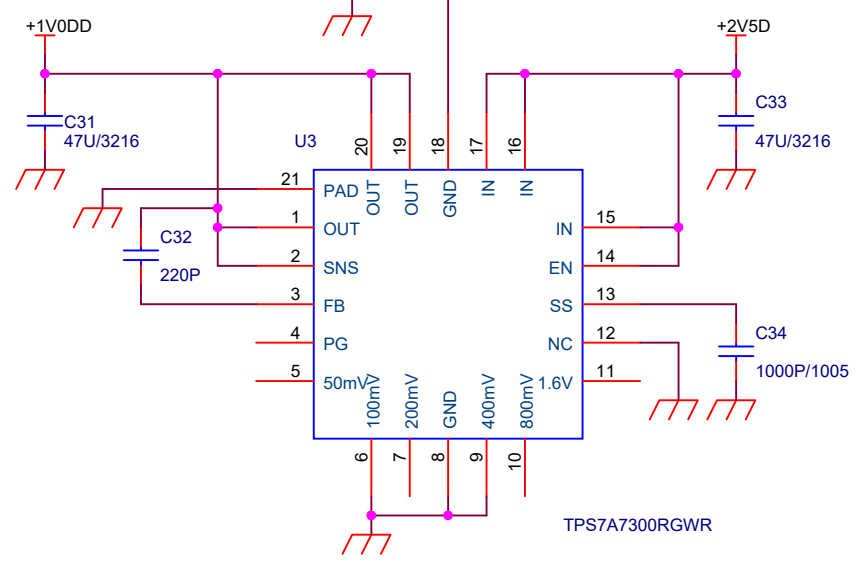

(+2.5V -> +1.0V) (3.0A)

For MGTAVTT (1.2V)

RiseTime about 13 msec

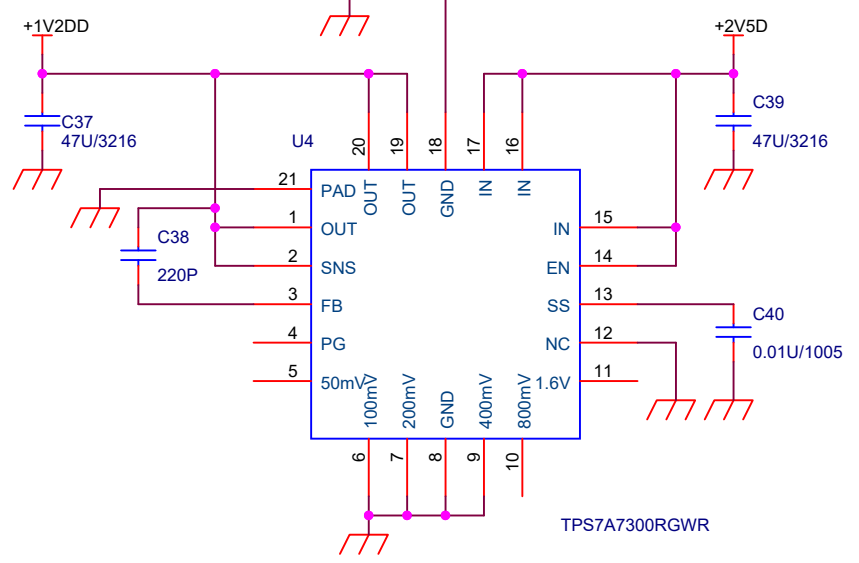

(+2.5V -> +1.2V) (3.0A)

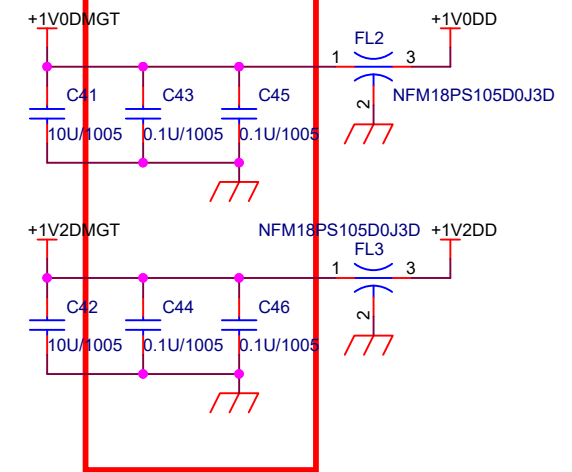

青字の配線は移動不可

U1G		+2V5D		
ADC_OUT_P8	F4	IO_0_35	VCCO_35	
ADC_OUT_N8	B1	IO_L1P_T0_AD4P_35	VCCO_35	
ADC_OUT_P9	A1	IO_L1N_T0_AD4N_35	VCCO_35	
ADC_OUT_N9	C2	IO_L2P_T0_AD12P_35	VCCO_35	
ADC_OUT_P10	B2	IO_L2N_T0_AD12N_35	VCCO_35	
ADC_OUT_N10	E1	IO_L3P_T0_DQS_AD5P_35	VCCO_35	
ADC2_CSB	D1	IO_L3N_T0_DQS_AD5N_35	VCCO_35	
ADC_OUT_P11	D2	IO_L4P_T0_35		
ADC_OUT_N11	G1	IO_L4N_T0_35		
	F1	IO_L5P_T0_AD13P_35	VCCO_35	
	F3	IO_L5N_T0_AD13N_35	VCCO_35	
	E3	IO_L6P_T0_35		
ADC_OUT_P13	K1	IO_L6N_T0_VREF_35		
ADC_OUT_N13	J1	IO_L7P_T1_AD6P_35		
ADC_OUT_P12	H2	IO_L7N_T1_AD6N_35		
ADC_OUT_N12	G2	IO_L8P_T1_AD14P_35		
ADC2_SCLK	K2	IO_L8N_T1_AD14N_35		
	J2	IO_L9P_T1_DQS_AD7P_35		
	J5	IO_L9N_T1_DQS_AD7N_35		
ADC2_SDIO	H5	IO_L10P_T1_AD15P_35		
	H3	IO_L10N_T1_AD15N_35		
ADC2_DCO+	G3	IO_L11P_T1_SRCC_35		
ADC2_DCO-	H4	IO_L11N_T1_SRCC_35		
ADC2_FCO+	G4	IO_L12P_T1_MRCC_35		
ADC2_FCO-	J4	IO_L12N_T1_MRCC_35		
	L3	IO_L13P_T2_MRCC_35		
	K3	IO_L13N_T2_MRCC_35		
ADC_OUT_P14	M1	IO_L14P_T2_SRCC_35		
ADC_OUT_N14	L1	IO_L14N_T2_SRCC_35		
	M3	IO_L15P_T2_DQS_35		
	M2	IO_L15N_T2_DQS_35		
	K6	IO_L16P_T2_35		
	J6	IO_L16N_T2_35		
	L5	IO_L17P_T2_35		
	L4	IO_L17N_T2_35		
	N4	IO_L18P_T2_35		
	N3	IO_L18N_T2_35		
ADC2_CLKP	R1	IO_L19P_T3_VREF_35		
ADC2_CLKN	P1	IO_L19N_T3_VREF_35		
	P5	IO_L20P_T3_35		
	P4	IO_L20N_T3_35		
ADC_OUT_P15	P2	IO_L21P_T3_DQS_35		
ADC_OUT_N15	N2	IO_L21N_T3_DQS_35		
	M6	IO_L22P_T3_35		
	M5	IO_L22N_T3_35		
	P6	IO_L23P_T3_35		
	N5	IO_L23N_T3_35		
	L6	IO_L24P_T3_35		
		IO_L24N_T3_35		
		IO_25_35		

XC7A100T-1FGG484C

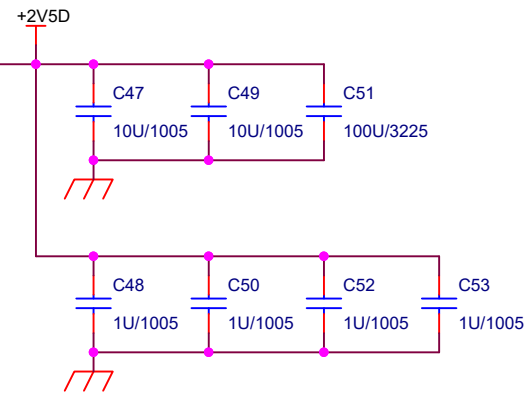

+2V5D

青字の配線は移動不可

U1F		+2V5D	
ADC_OUT_P0	T3	IO_0_34	VCCO_34
ADC_OUT_N0	T1	IO_L1P_T0_34	VCCO_34
ADC1_SDIO	U1	IO_L1N_T0_34	VCCO_34
	U2	IO_L2P_T0_34	VCCO_34
ADC1_CSB	V2	IO_L2N_T0_34	VCCO_34
	R3	IO_L3P_T0_DQS_34	VCCO_34
ADC_OUT_P2	R2	IO_L3N_T0_DQS_34	VCCO_34
ADC_OUT_N2	W2	IO_L4P_T0_34	
ADC_OUT_P1	Y2	IO_L4N_T0_34	
ADC_OUT_N1	W1	IO_L5P_T0_34	
ADC1_SCLK	U3	IO_L5N_T0_34	
	V3	IO_L6P_T0_34	
ADC_OUT_P3	AA1	IO_L6N_T0_VREF_34	
ADC_OUT_N3	AB1	IO_L7P_T1_34	
	AB3	IO_L7N_T1_34	
	AB2	IO_L8P_T1_34	
ADC_OUT_P5	Y3	IO_L8N_T1_34	
ADC_OUT_N5	AA3	IO_L9P_T1_DQS_34	
ADC_OUT_P4	AA5	IO_L9N_T1_DQS_34	
ADC_OUT_N4	AB5	IO_L10P_T1_34	
	Y4	IO_L10N_T1_34	
	AA4	IO_L11P_T1_SRCC_34	
ADC1_DCO+	V4	IO_L11N_T1_SRCC_34	
ADC1_DCO-	W4	IO_L12P_T1_MRCC_34	
ADC1_FCO+	R4	IO_L12N_T1_MRCC_34	
ADC1_FCO-	T4	IO_L13P_T2_MRCC_34	
	T5	IO_L13N_T2_MRCC_34	
	U5	IO_L14P_T2_SRCC_34	
	W6	IO_L14N_T2_SRCC_34	
	W5	IO_L15P_T2_DQS_34	
	U6	IO_L15N_T2_DQS_34	
	V5	IO_L16P_T2_34	
	R6	IO_L16N_T2_34	
	T6	IO_L17P_T2_34	
ADC_OUT_P6	Y6	IO_L17N_T2_34	
ADC_OUT_N6	AA6	IO_L18P_T2_34	
	V7	IO_L18N_T2_34	
	W7	IO_L19P_T3_34	
	AB7	IO_L19N_T3_VREF_34	
	AB6	IO_L20P_T3_34	
	V9	IO_L20N_T3_34	
	V8	IO_L21P_T3_DQS_34	
ADC_OUT_P7	AA8	IO_L21N_T3_DQS_34	
ADC_OUT_N7	AB8	IO_L22P_T3_34	
	Y8	IO_L22N_T3_34	
	Y7	IO_L23P_T3_34	
ADC1_CLKP	W9	IO_L23N_T3_34	
ADC1_CLKN	Y9	IO_L24P_T3_34	
	U7	IO_L24N_T3_34	
		IO_25_34	

XC7A100T-1FGG484C

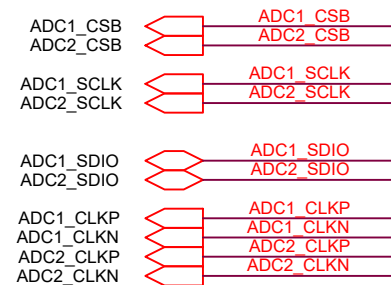
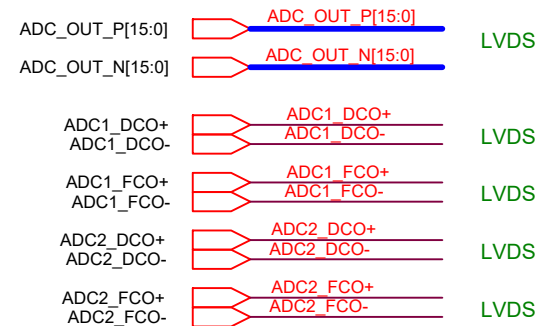
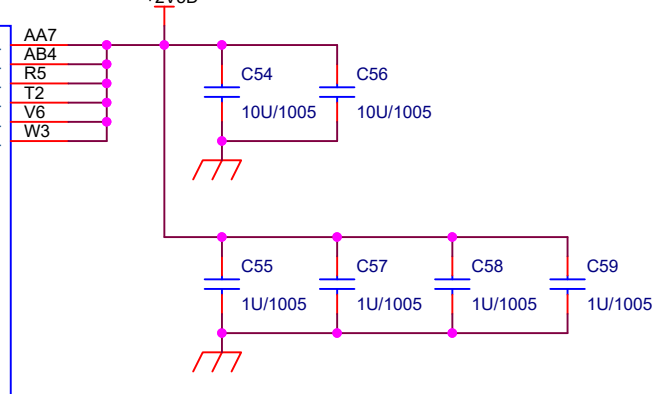

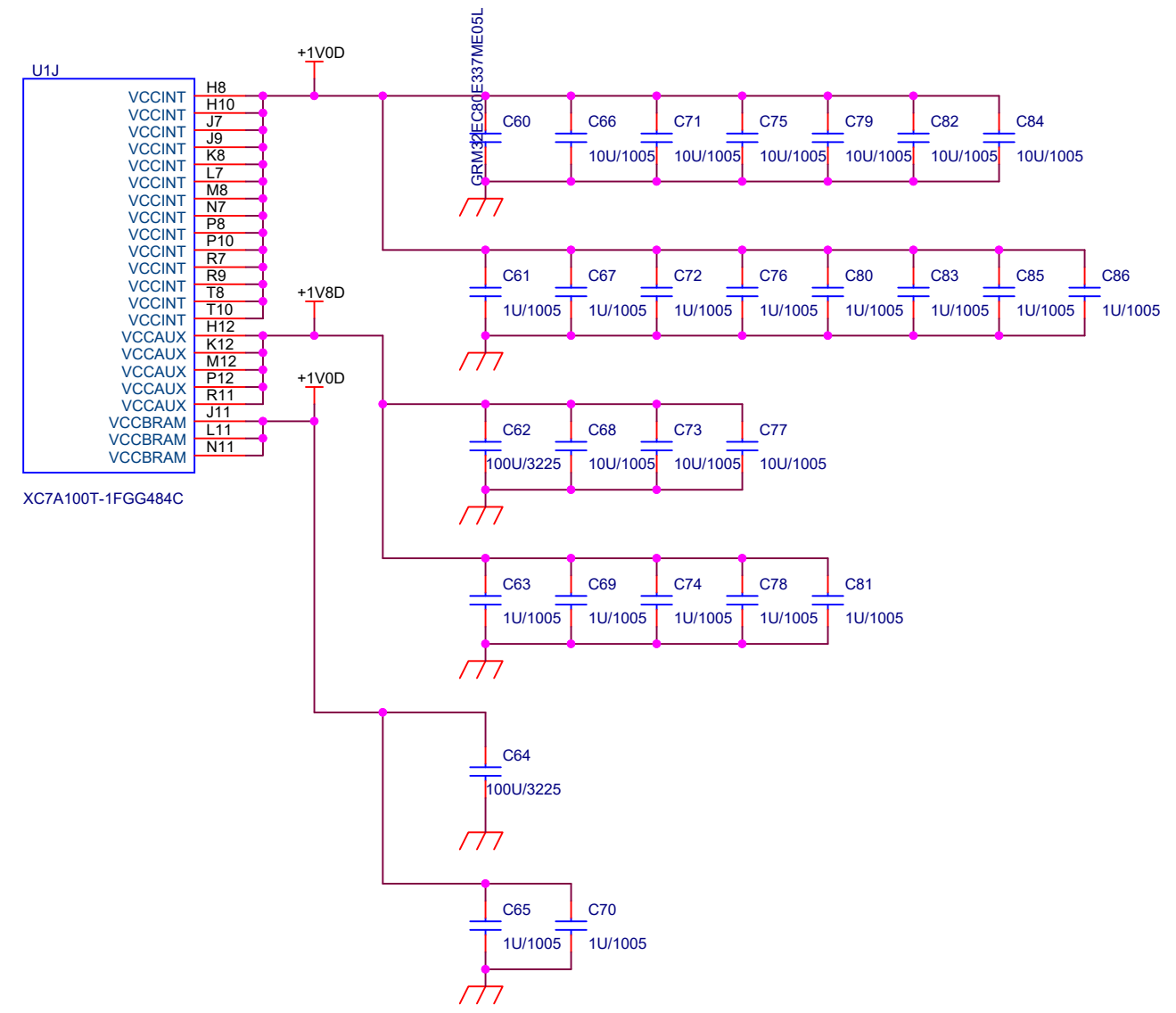
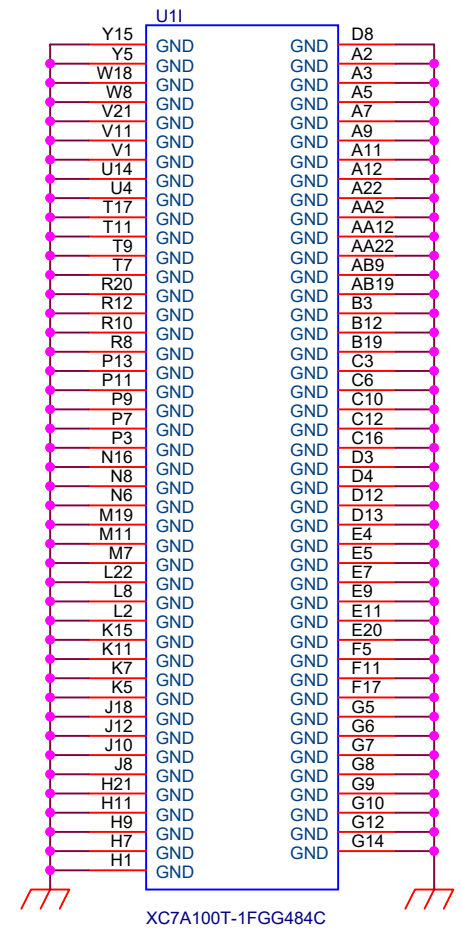

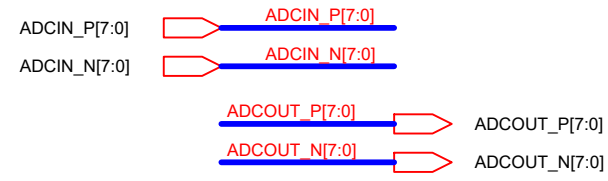

LVDS

230801 配線の流れを良くするため逆順に変更

半田面に置く

ADCの近くには置かない

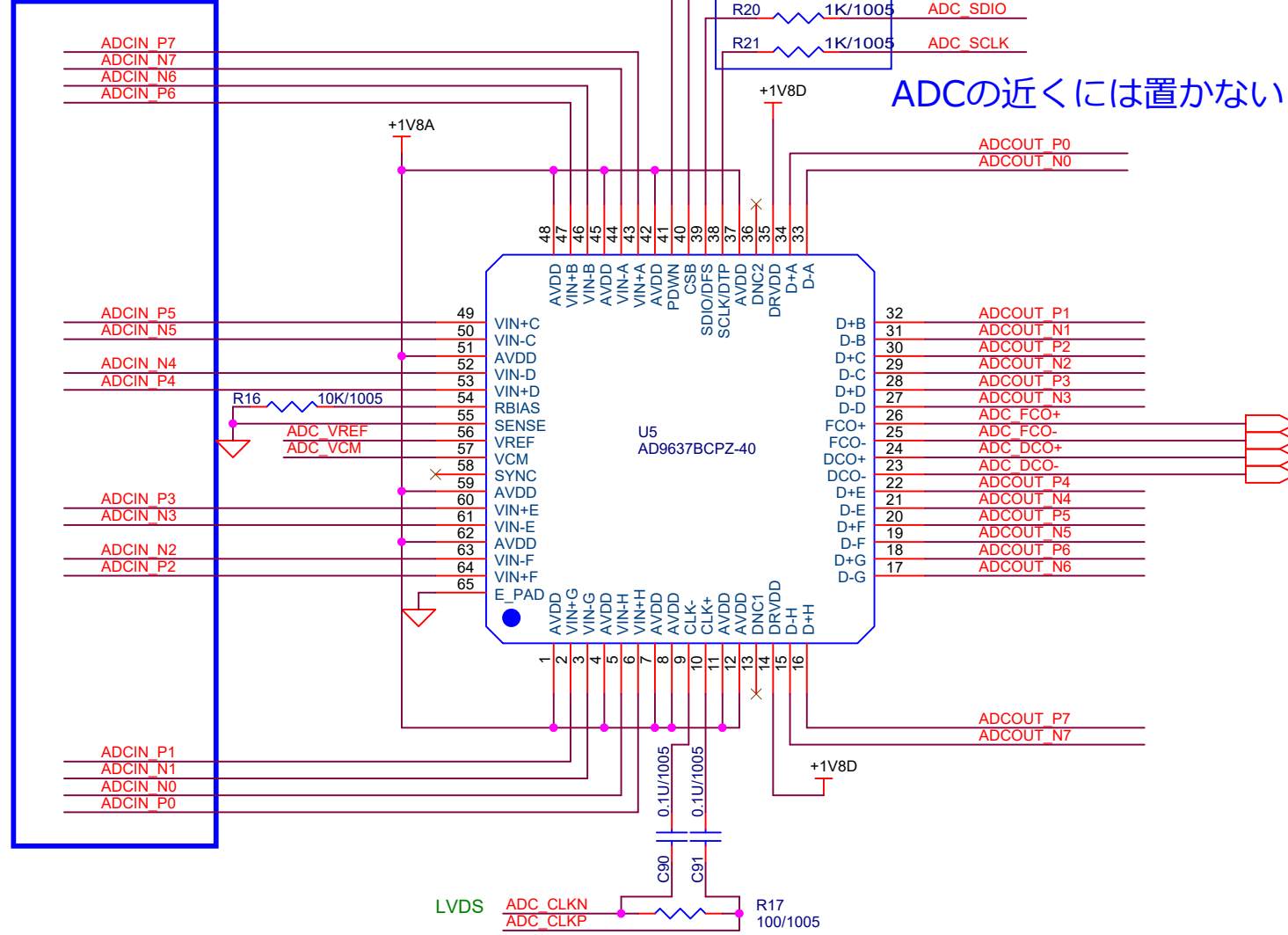

LVDS

LVDS
LVDS

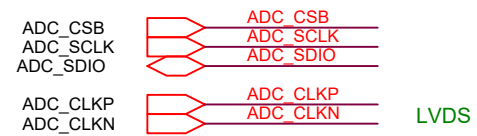
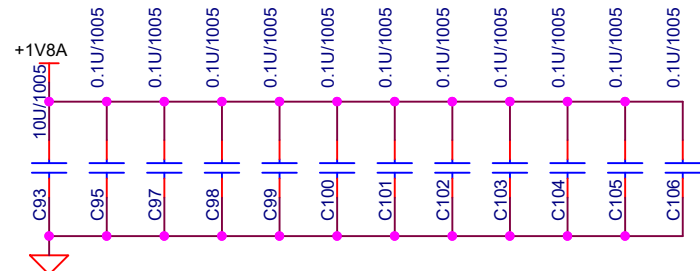
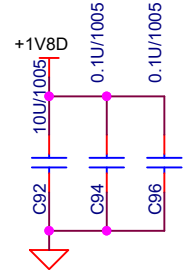
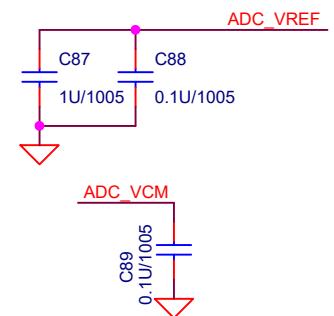

ADC_SITCP V.2		
Title ADC (8-CH)		
Size A3	Document Number <Doc>	Rev <RevC>
Date: Tuesday, August 01, 2023	Sheet 9	of 23

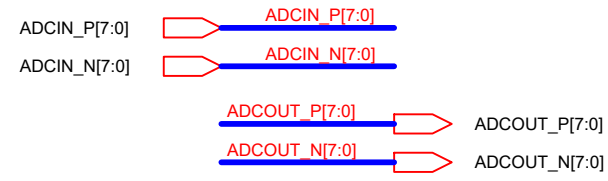

LVDS

230801 配線の流れを良くするため逆順に変更

半田面に置く

ADCの近くには置かない

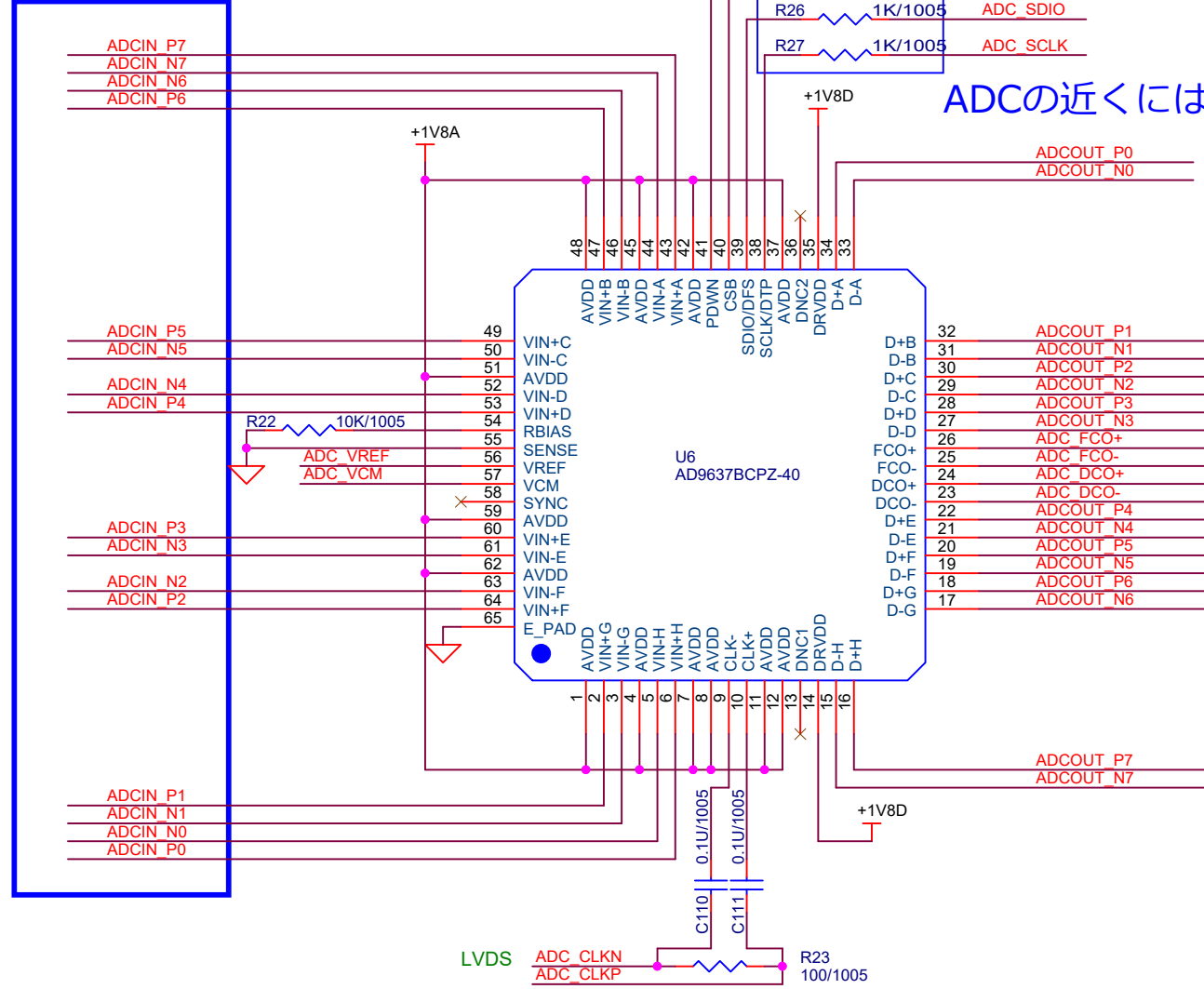

LVDS

LVDS
LVDS

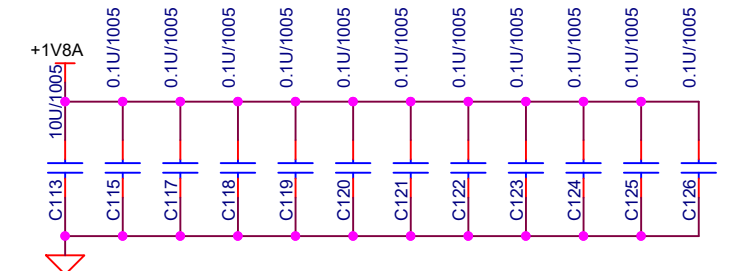
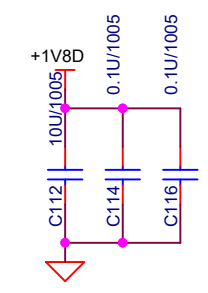
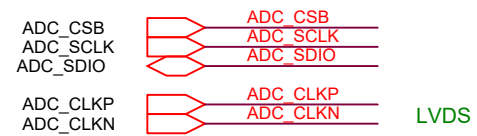

ADC_SITCP V.2		
Title		
ADC (8-CH)		
Size	Document Number	Rev
A3	<Doc>	<RevC>
Date:	Tuesday, August 01, 2023	Sheet 10 of 23

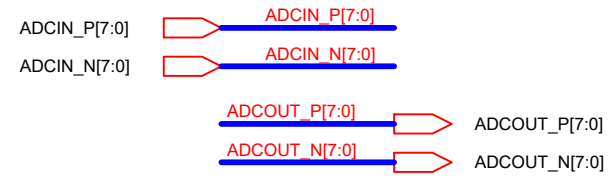

LVDS

230801 配線の流れを良くするため逆順に変更

半田面に置く

ADCの近くには置かない

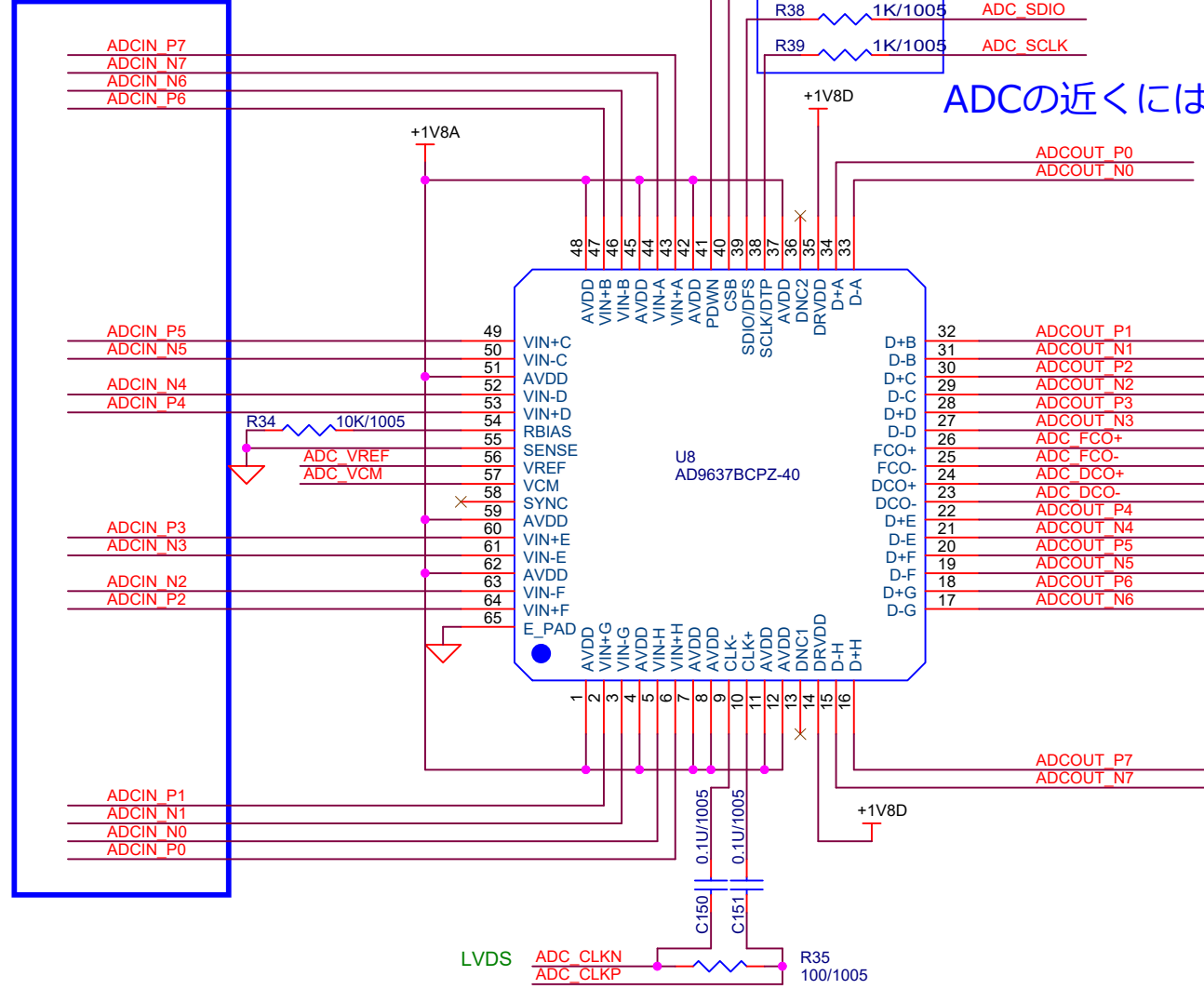

ADC_FCO+
 ADC_FCO-
 ADC_DCO+
 ADC_DCO-
 LVDS
 LVDS

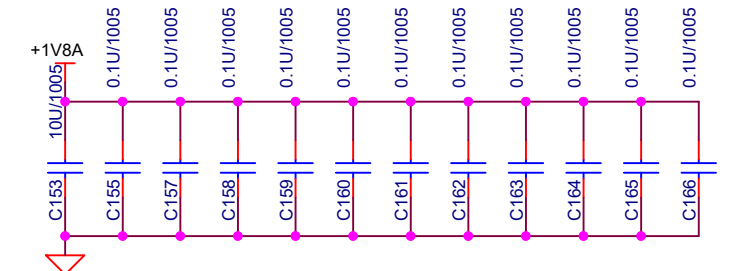
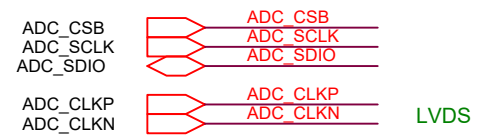
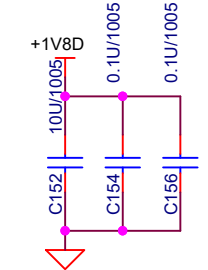
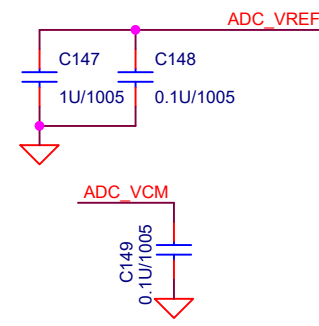

ADC_SITCP V.2		
Title ADC (8-CH)		
Size A3	Document Number <Doc>	Rev <RevC>
Date: Tuesday, August 01, 2023	Sheet 12	of 23

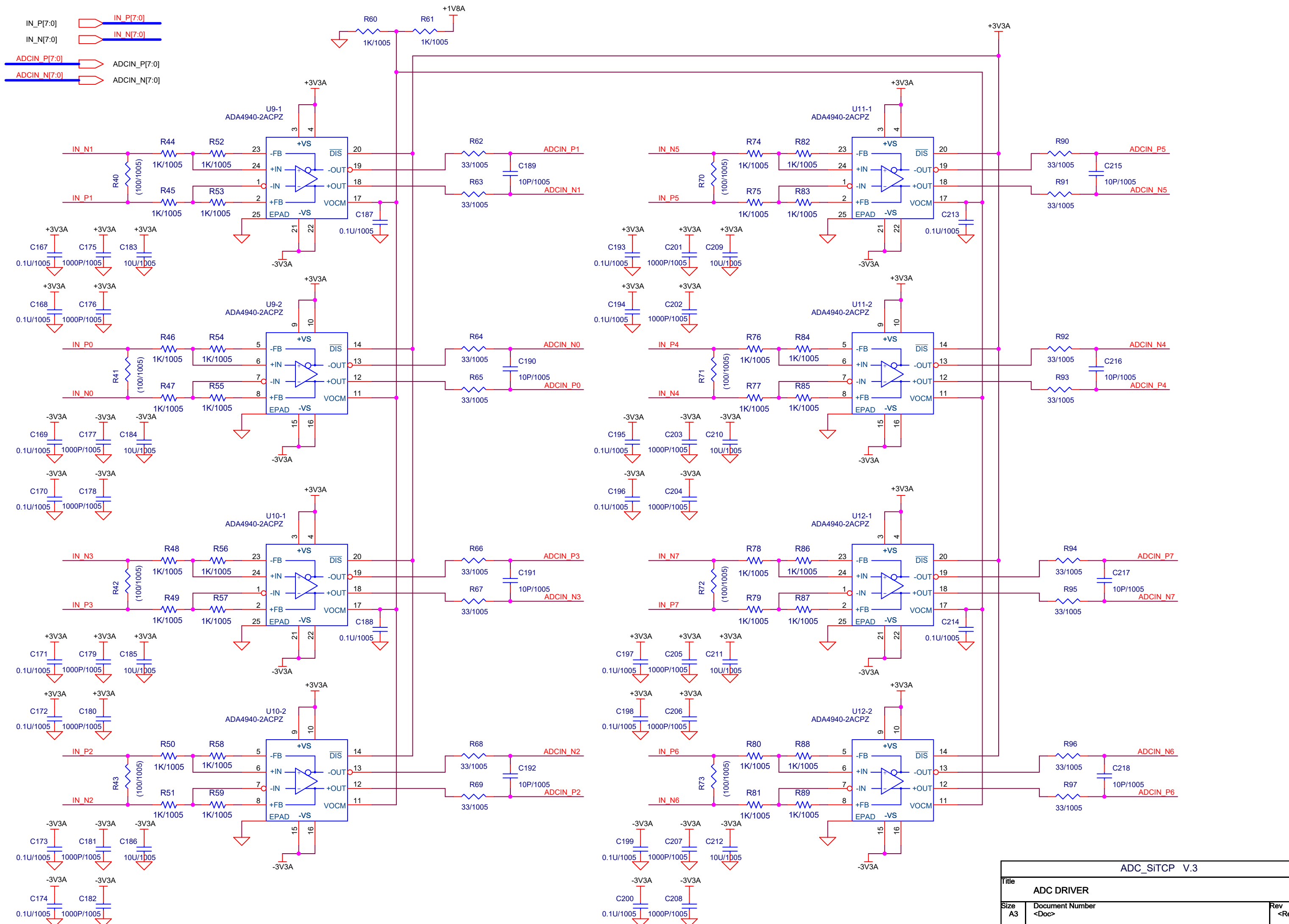

Title			ADC DRIVER		
Size	Document Number		Rev		
A3	<Doc>		<RevC		
Date:	Tuesday, August 01, 2023	Sheet	13	of	23

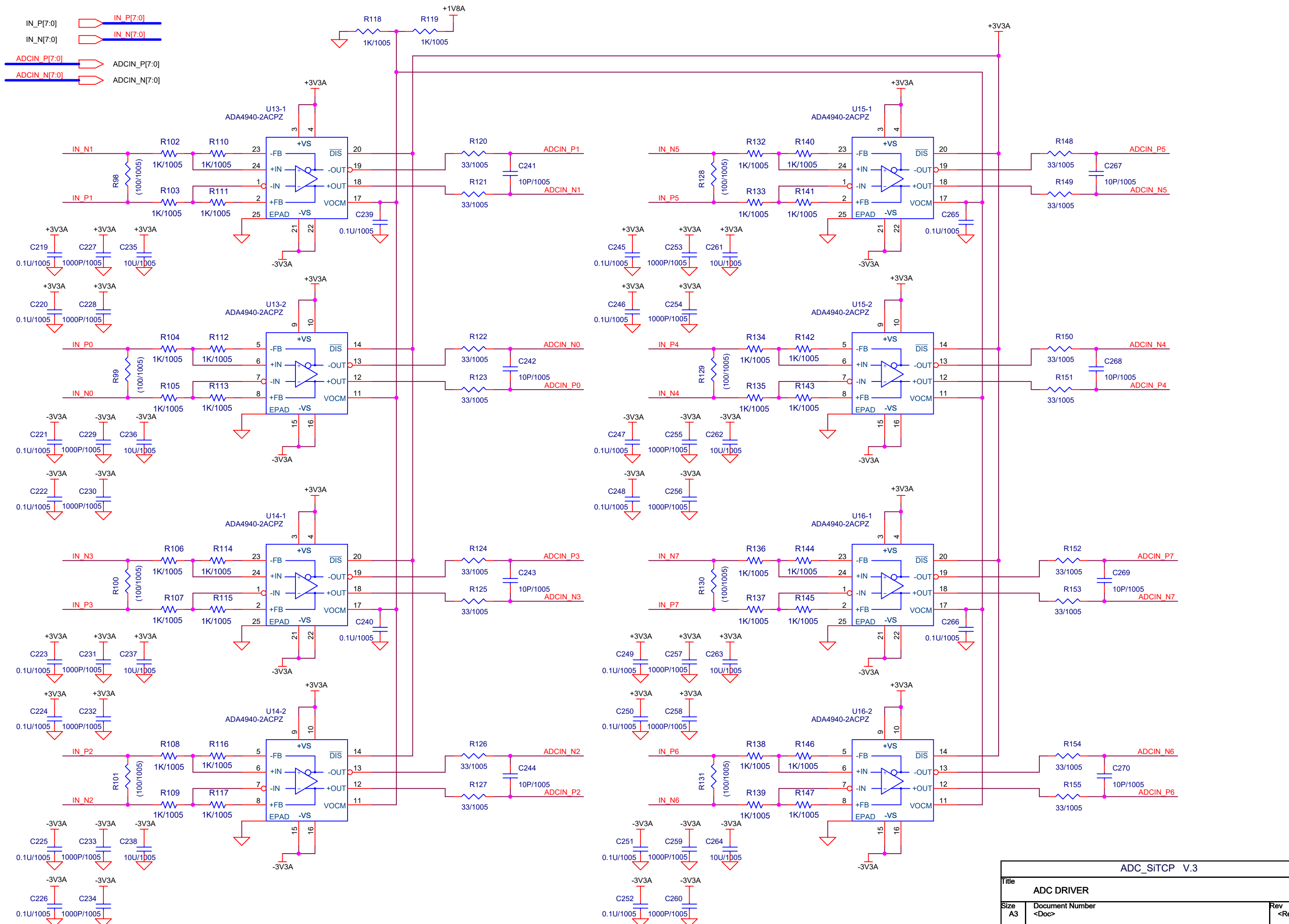

Title			ADC DRIVER		
Size	Document Number		Rev		
A3	<Doc>		<RevC>		
Date:	Tuesday, August 01, 2023	Sheet	14	of	23

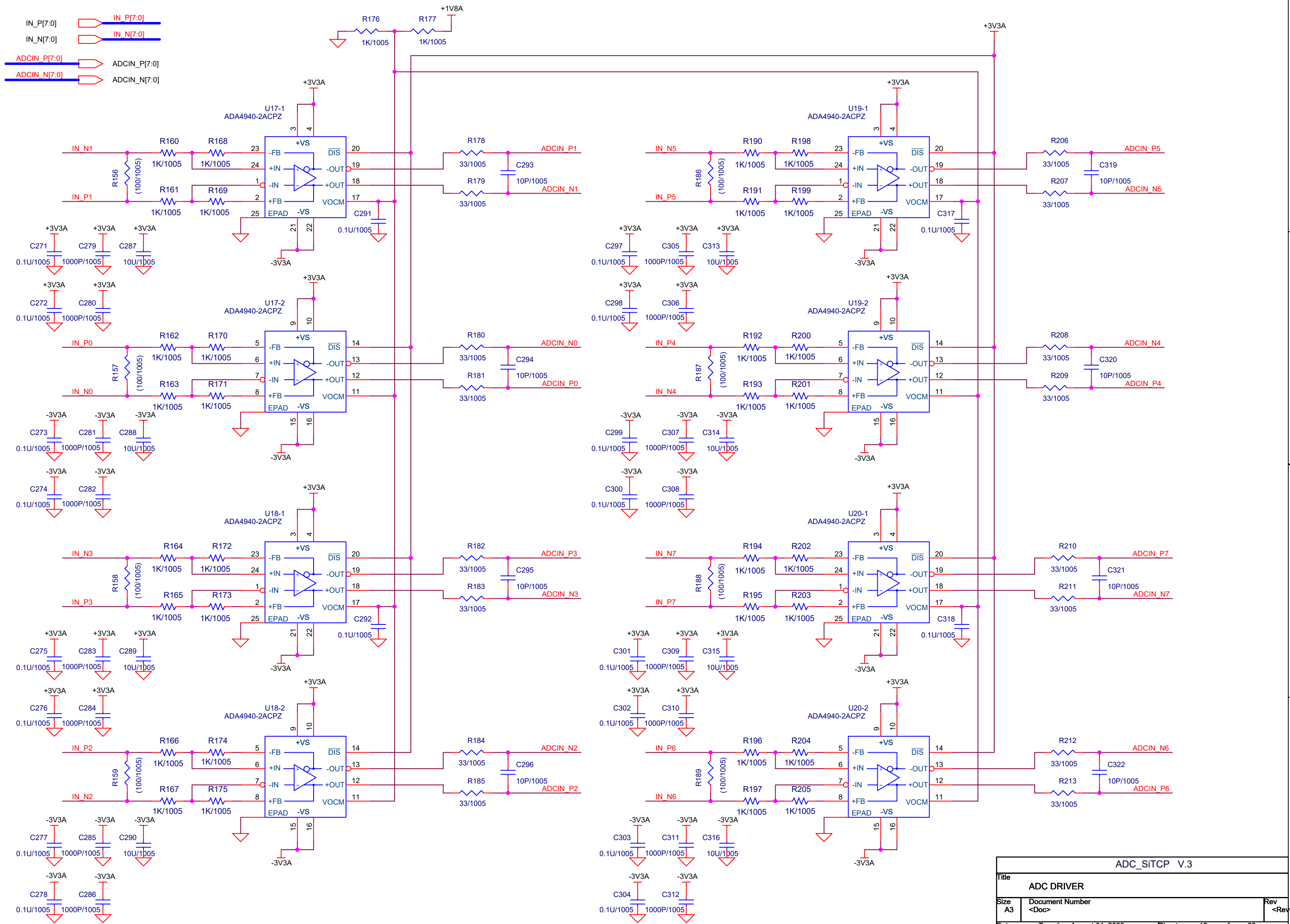

Title		
ADC DRIVER		
Size	Document Number	Rev
A3	<Doc>	<RevC>
Date:	Tuesday, August 01, 2023	Sheet 15 of 23

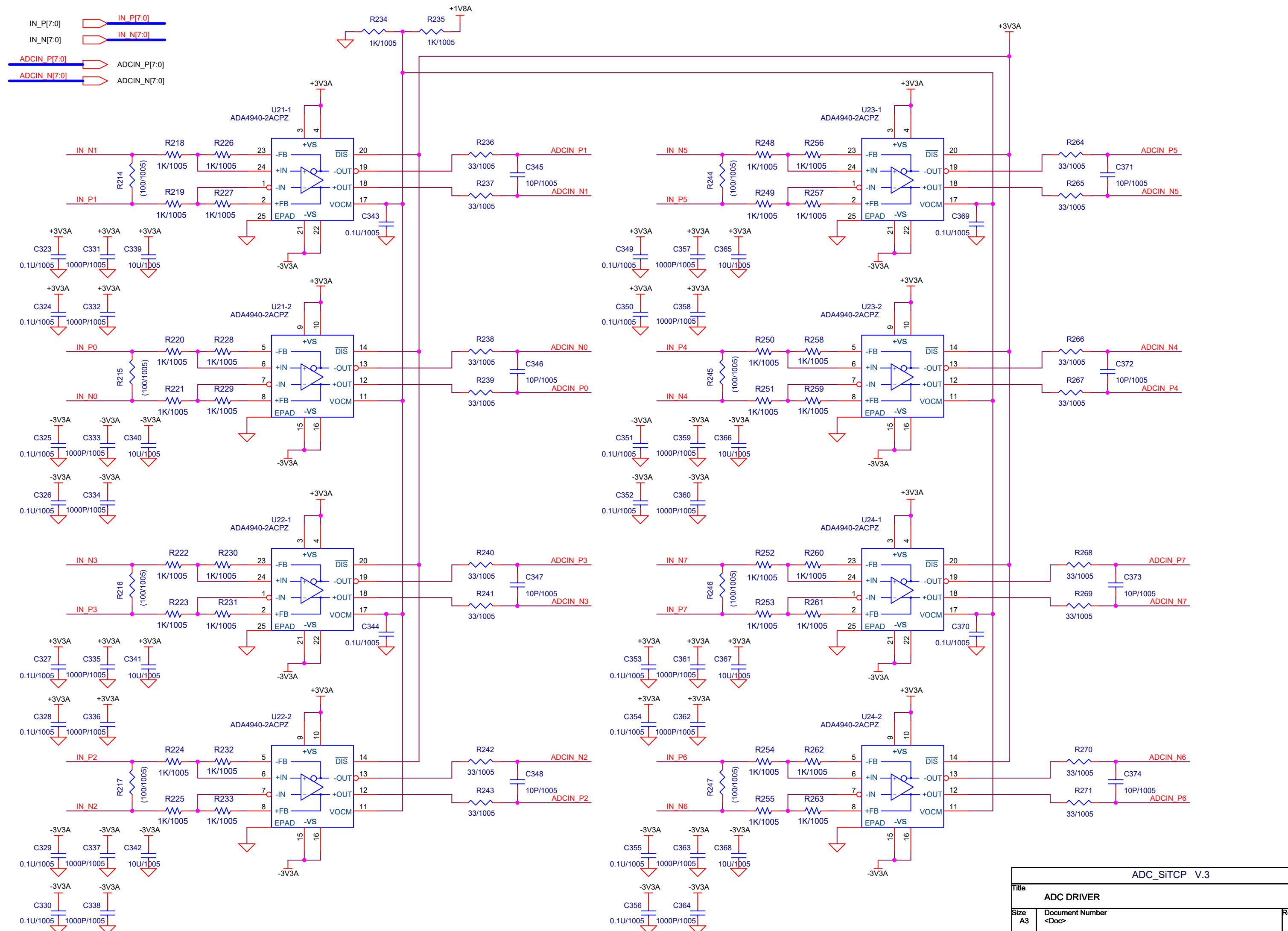

Title			ADC DRIVER		
Size	Document Number		Rev		
A3	<Doc>		<RevC>		
Date:	Tuesday, August 01, 2023	Sheet	16	of	23

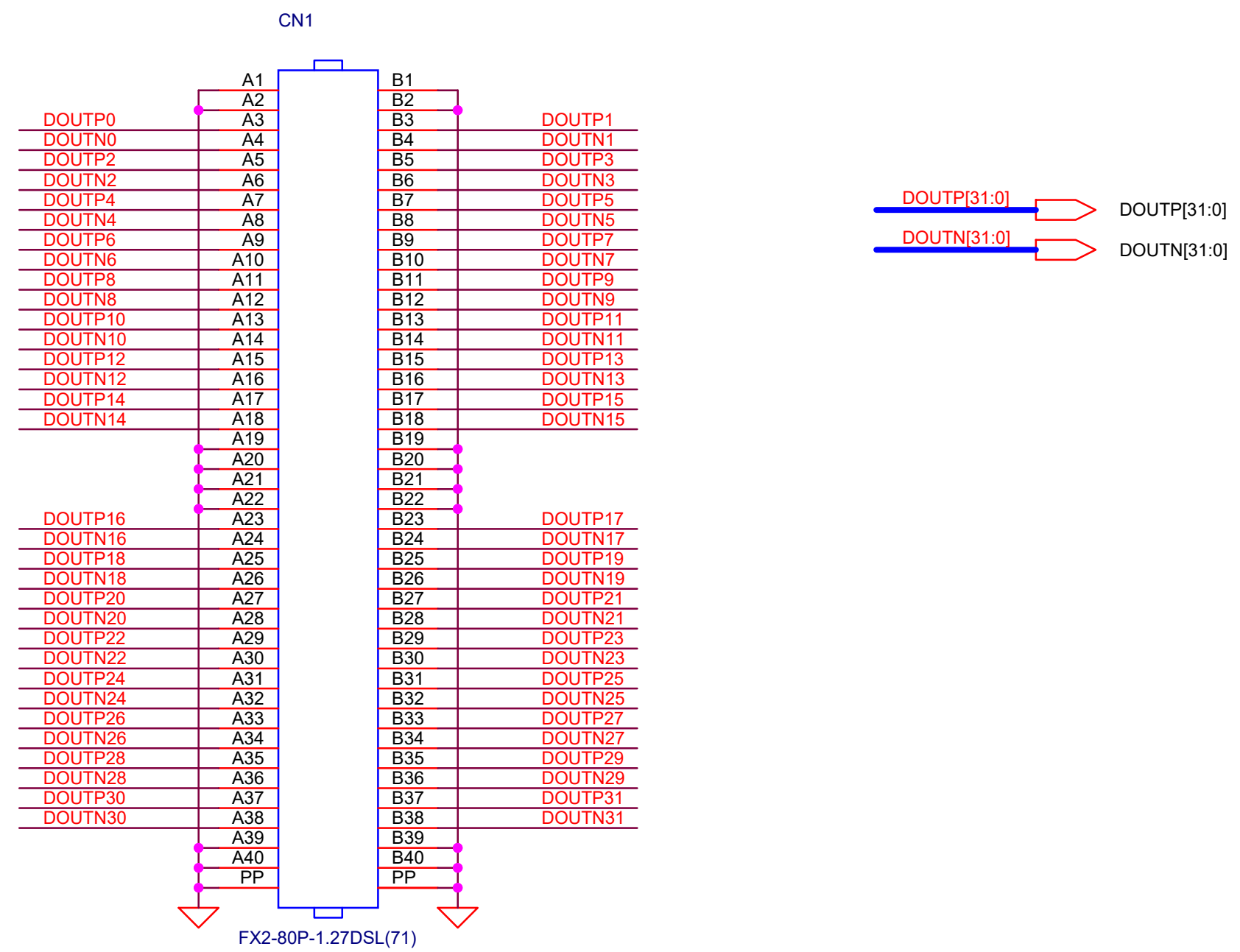

PP : コネクタ両端の基板仮止めピン
GNDに接続

ADC_SiTCP V.3		
Title		
ANALOG_IN		
Size	Document Number	Rev
A4	<Doc>	<RevCo
Date:	Tuesday, August 01, 2023	Sheet 17 of 23

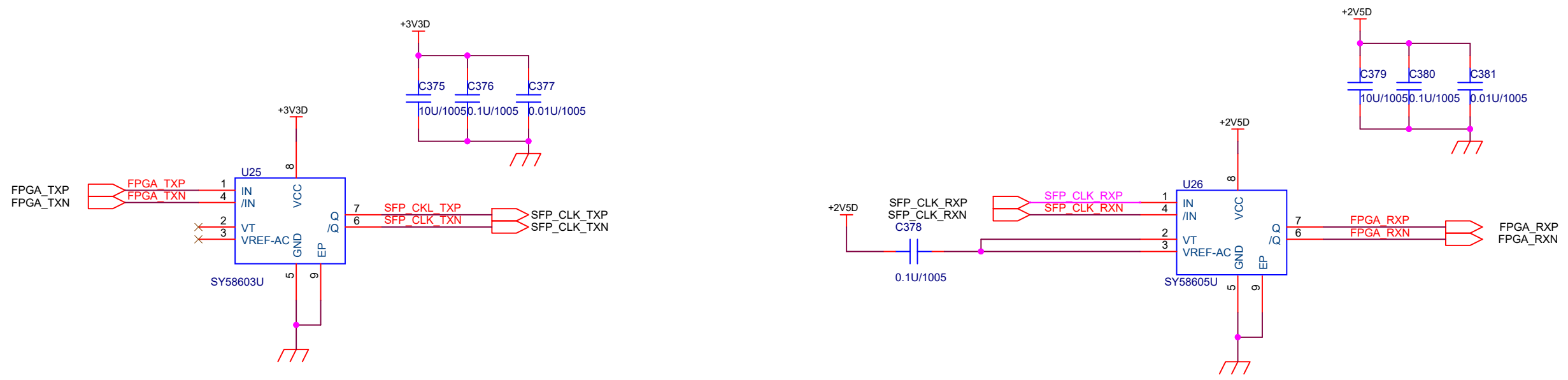

Title		
LVDS2CML,CML2LVDS		
Size	Document Number	Rev
A3	<Doc>	<RevCode>
Date:	Tuesday, August 01, 2023	Sheet 18 of 23

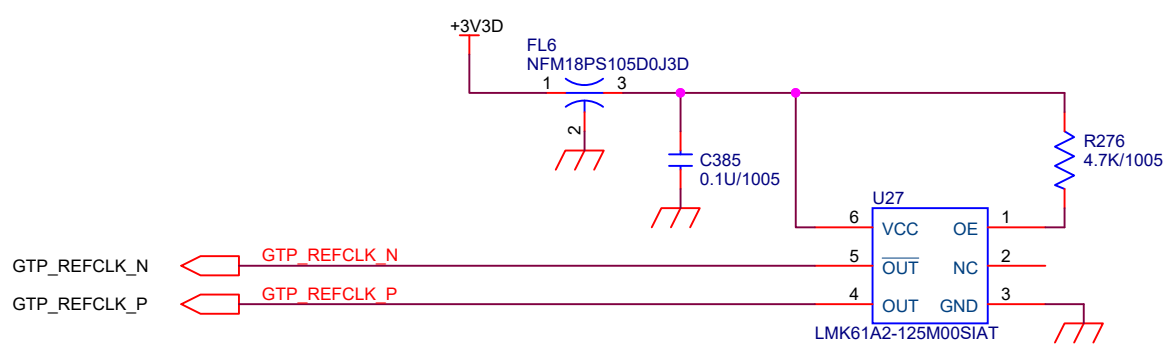
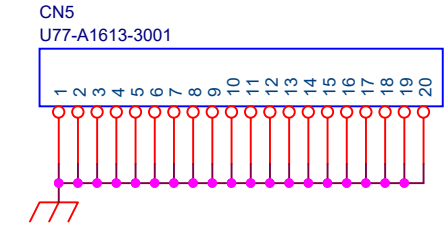
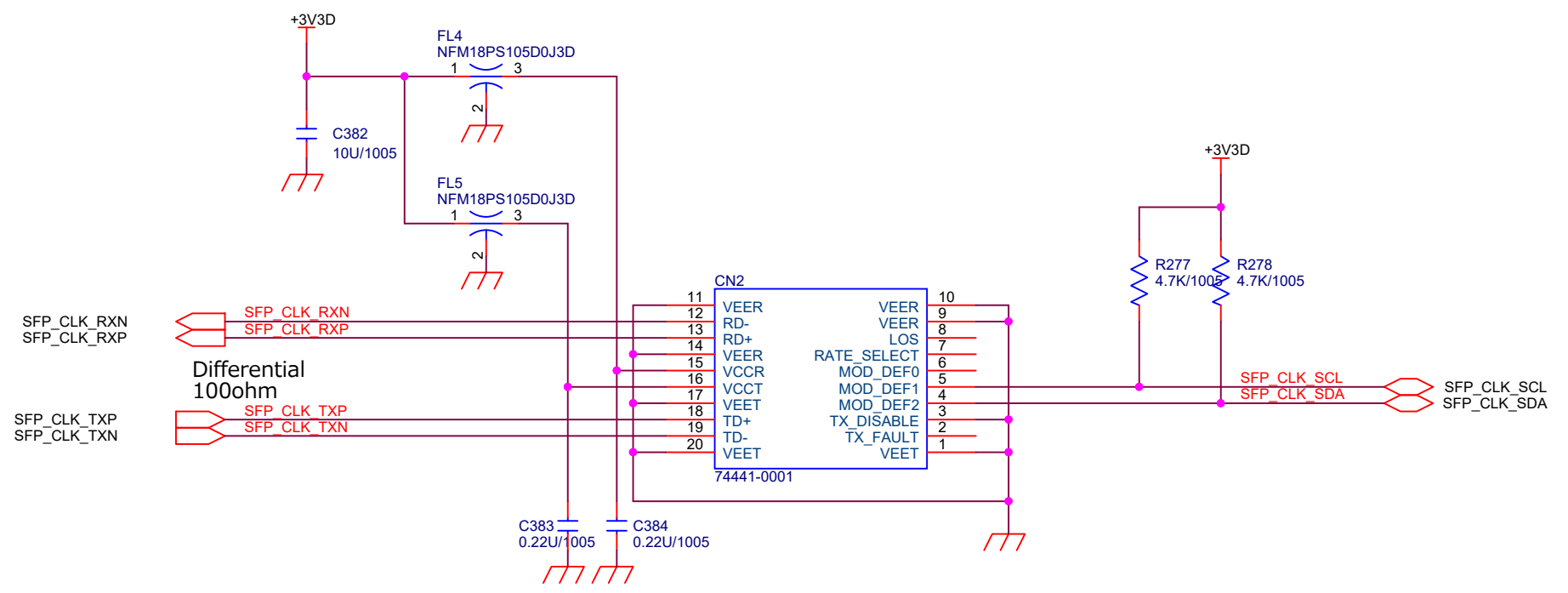
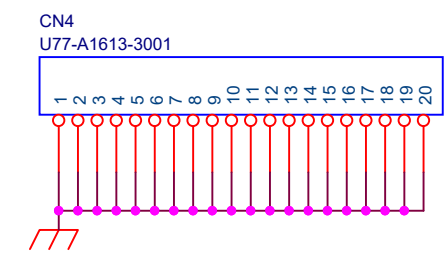
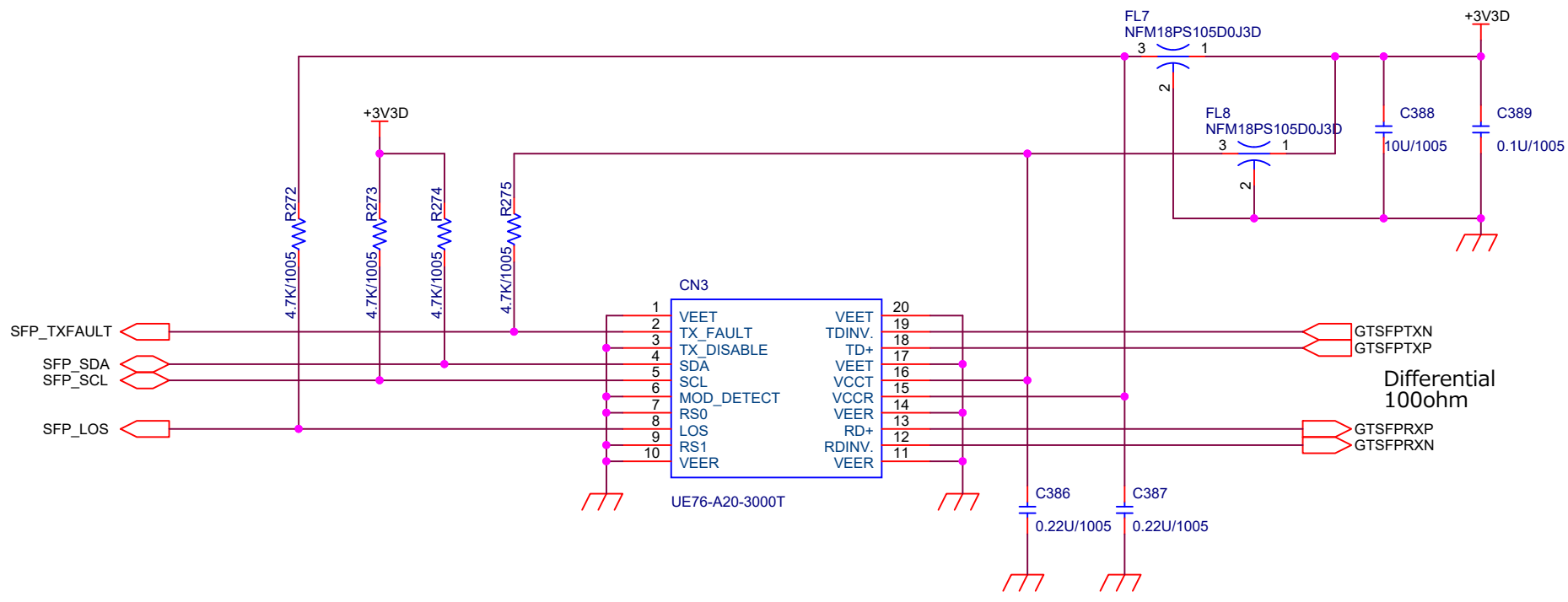

Title		
ADC SiTCP V.3		
SFP		
Size	Document Number	Rev
A3	<Doc>	1
Date:	Tuesday, August 15, 2023	Sheet 19 of 23

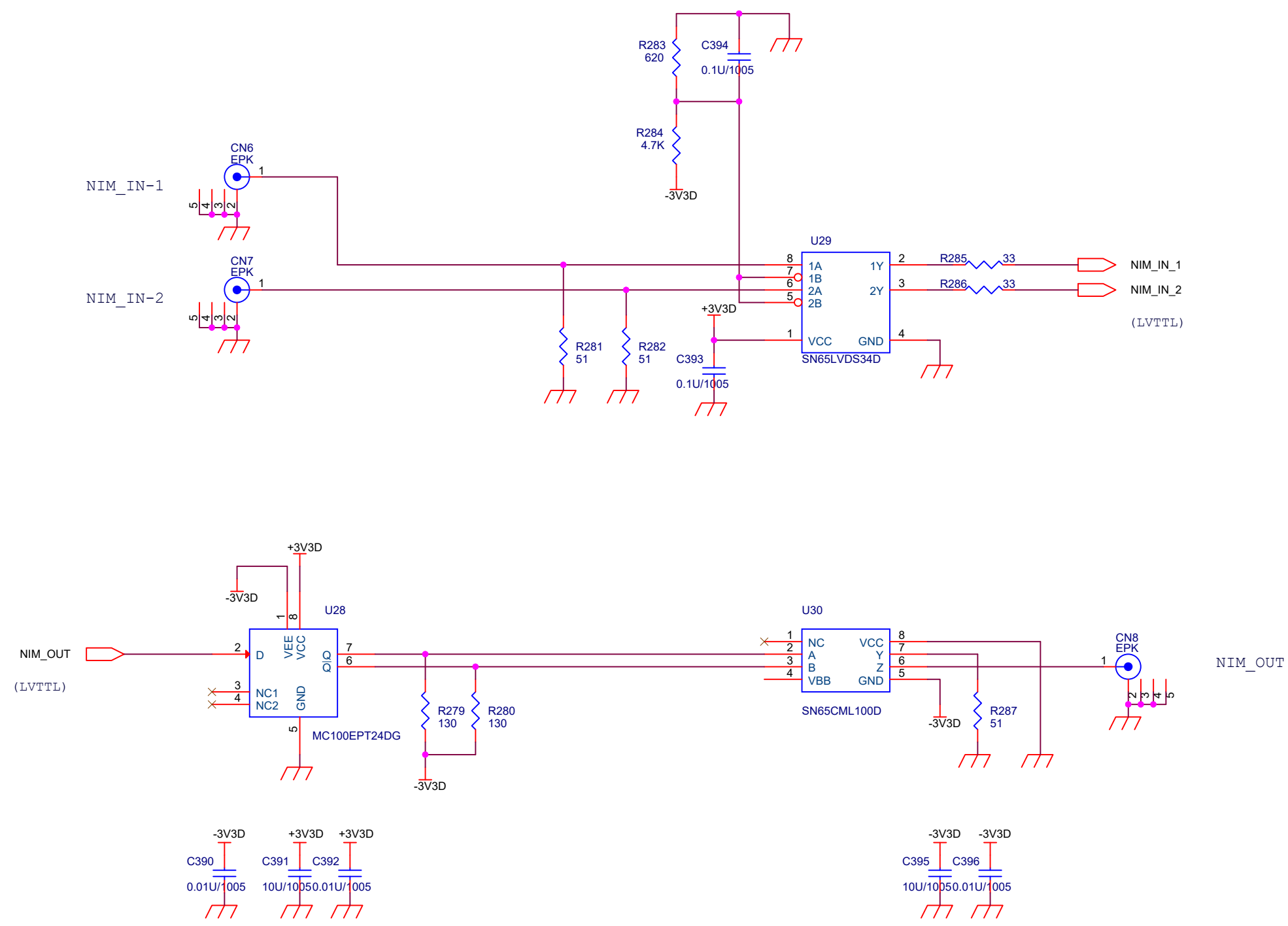

ADC_SITCP V.3		
Title		
NIM_IN / OUT		
Size	Document Number	Rev
A3	<Doc>	<RevC
Date:	Tuesday, August 01, 2023	Sheet 20 of 23

JTAG

Top View

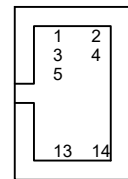

JTAG

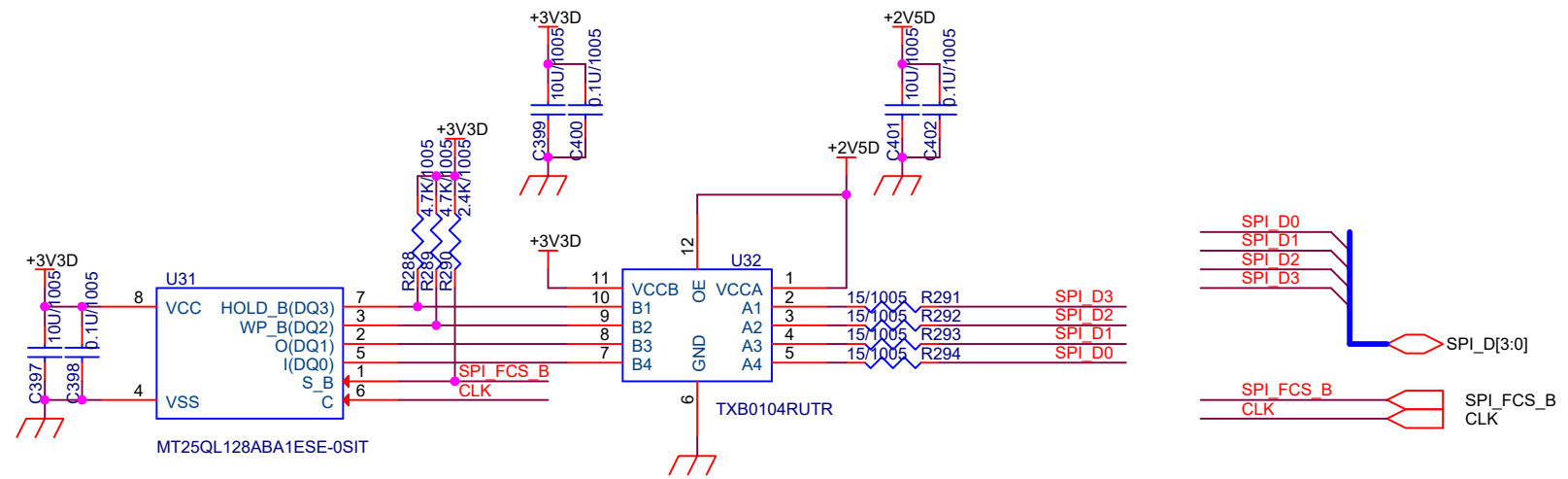
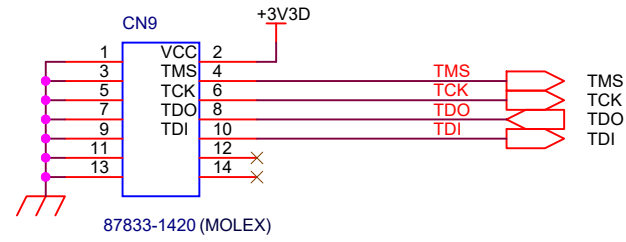

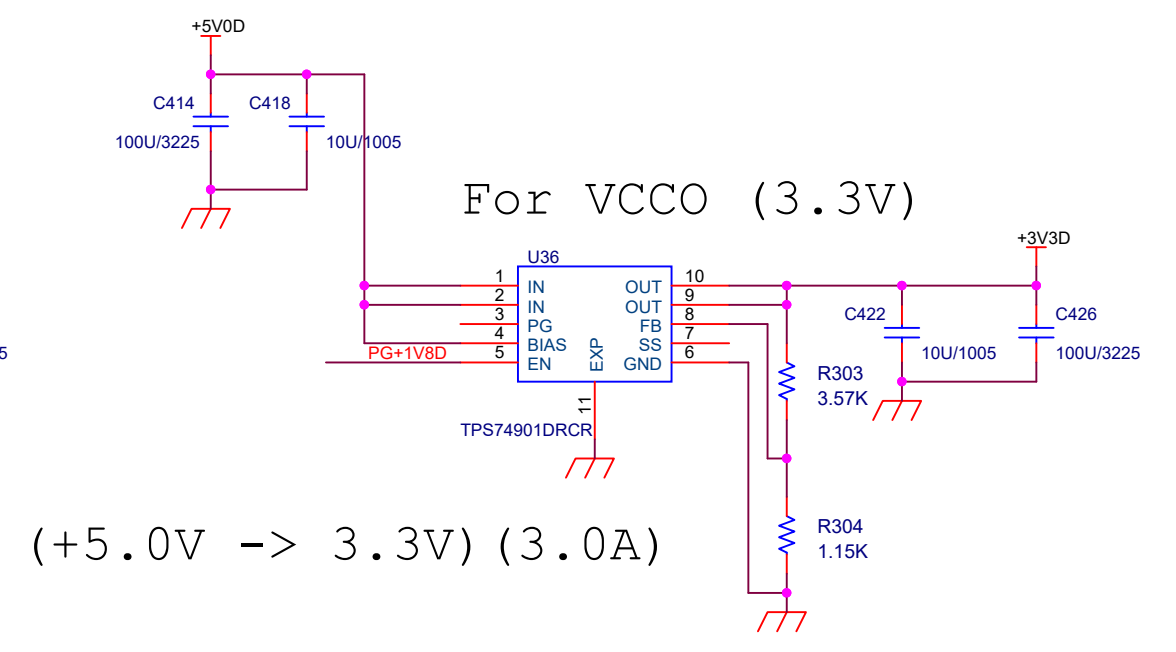
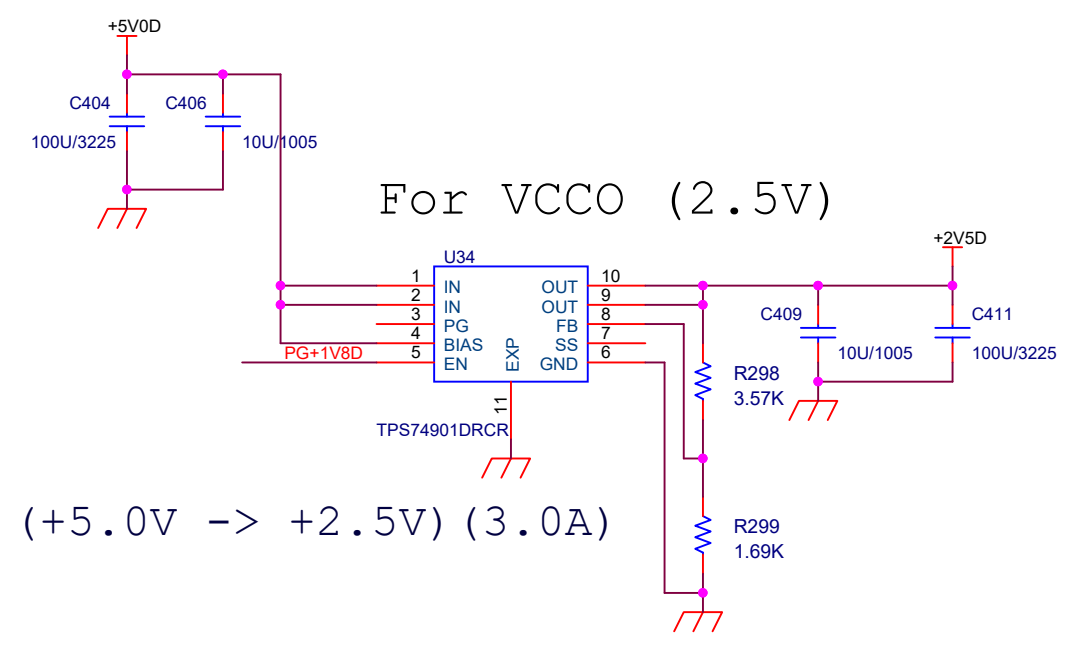
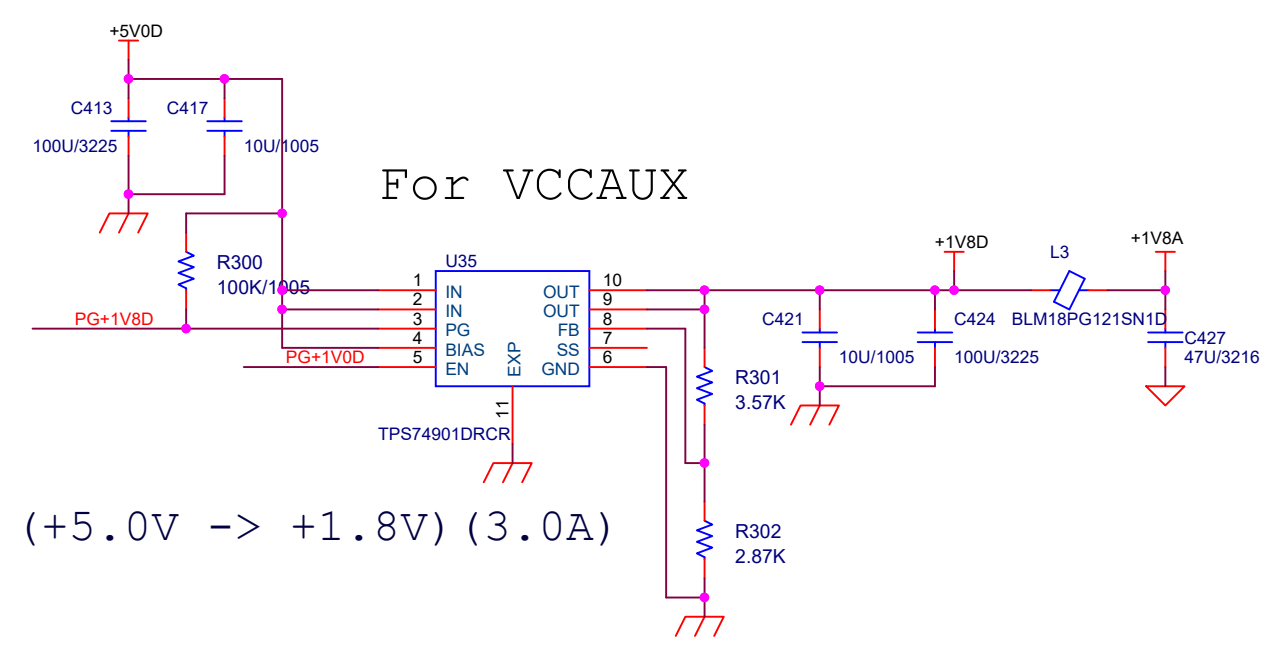
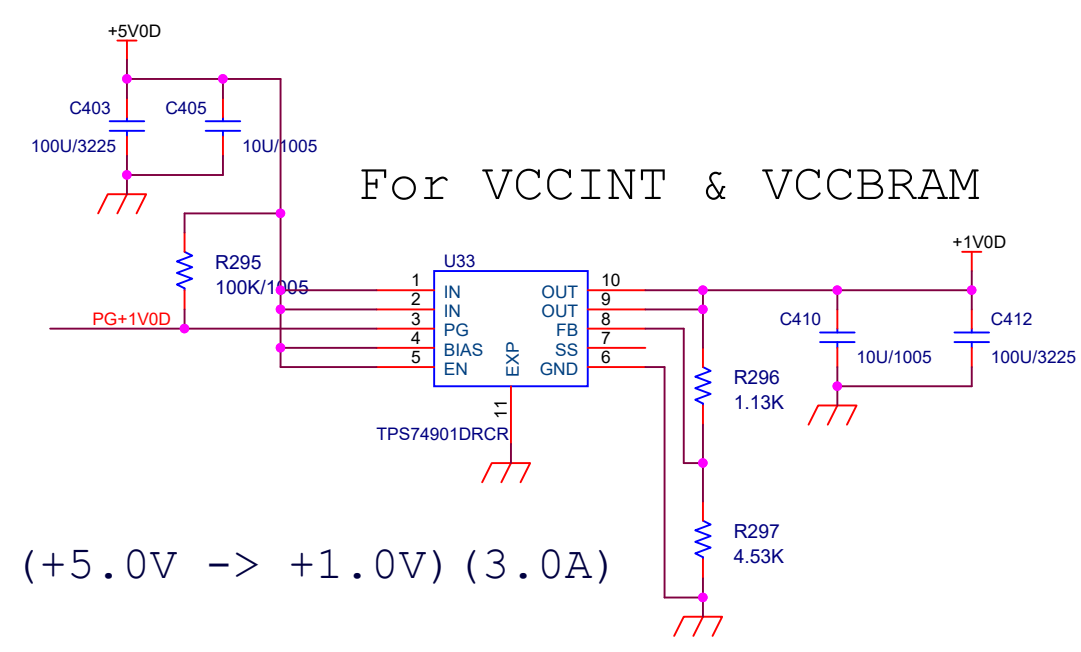
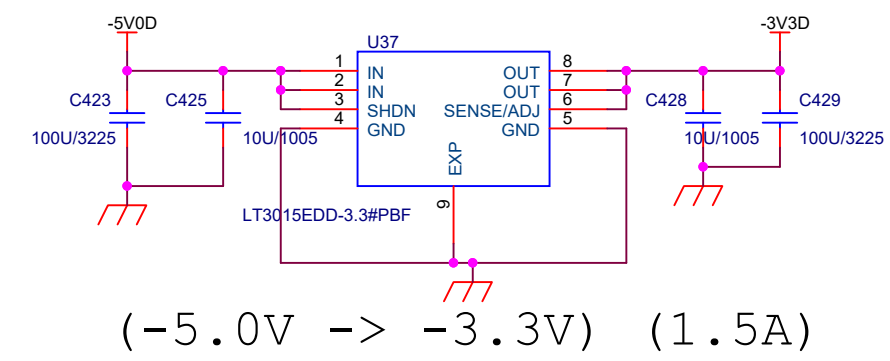
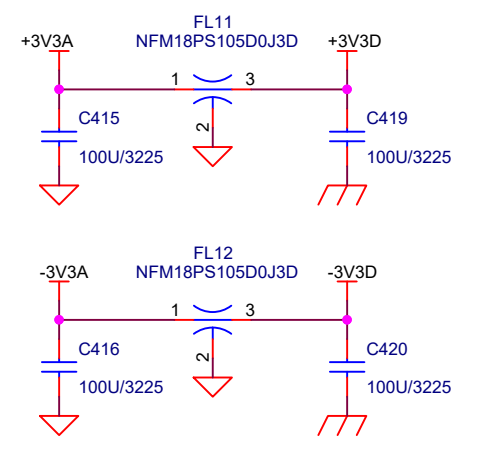
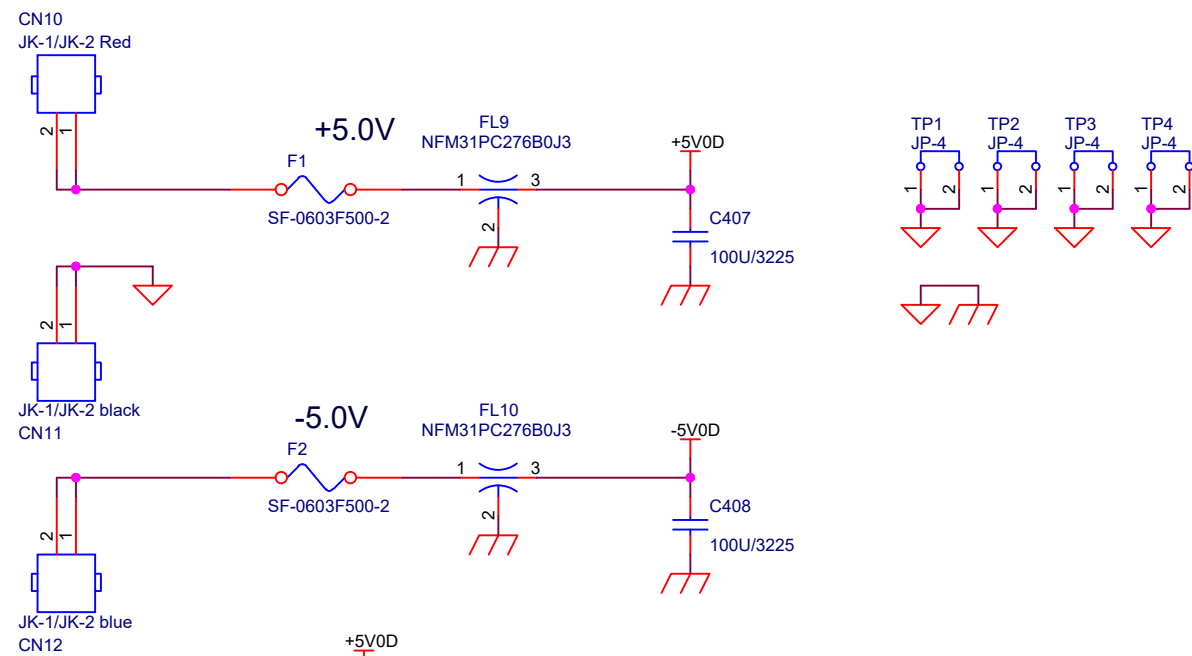

Title <Title>		
Size A3	Document Number <Doc>	Rev <Rev>
Date: Tuesday, August 01, 2023	Sheet 22	of 23

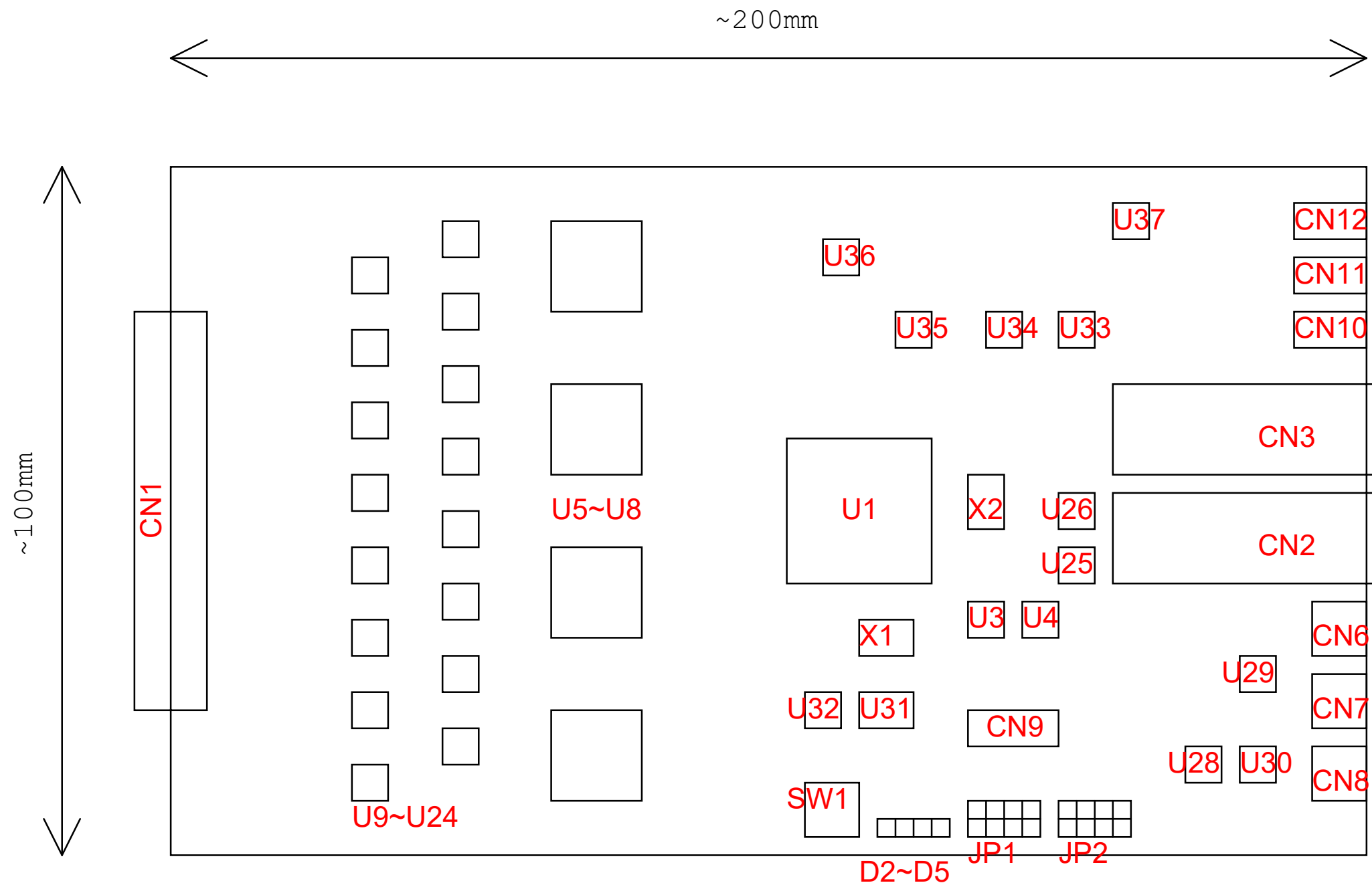

Title		
<Title>		
Size	Document Number	Rev
A4	<Doc>	<Rev>
Date:	Tuesday, August 01, 2023	Sheet 23 of 23